

REVISIONS				
ZONE	REV.	DESCRIPTION	DATE	APPROVED

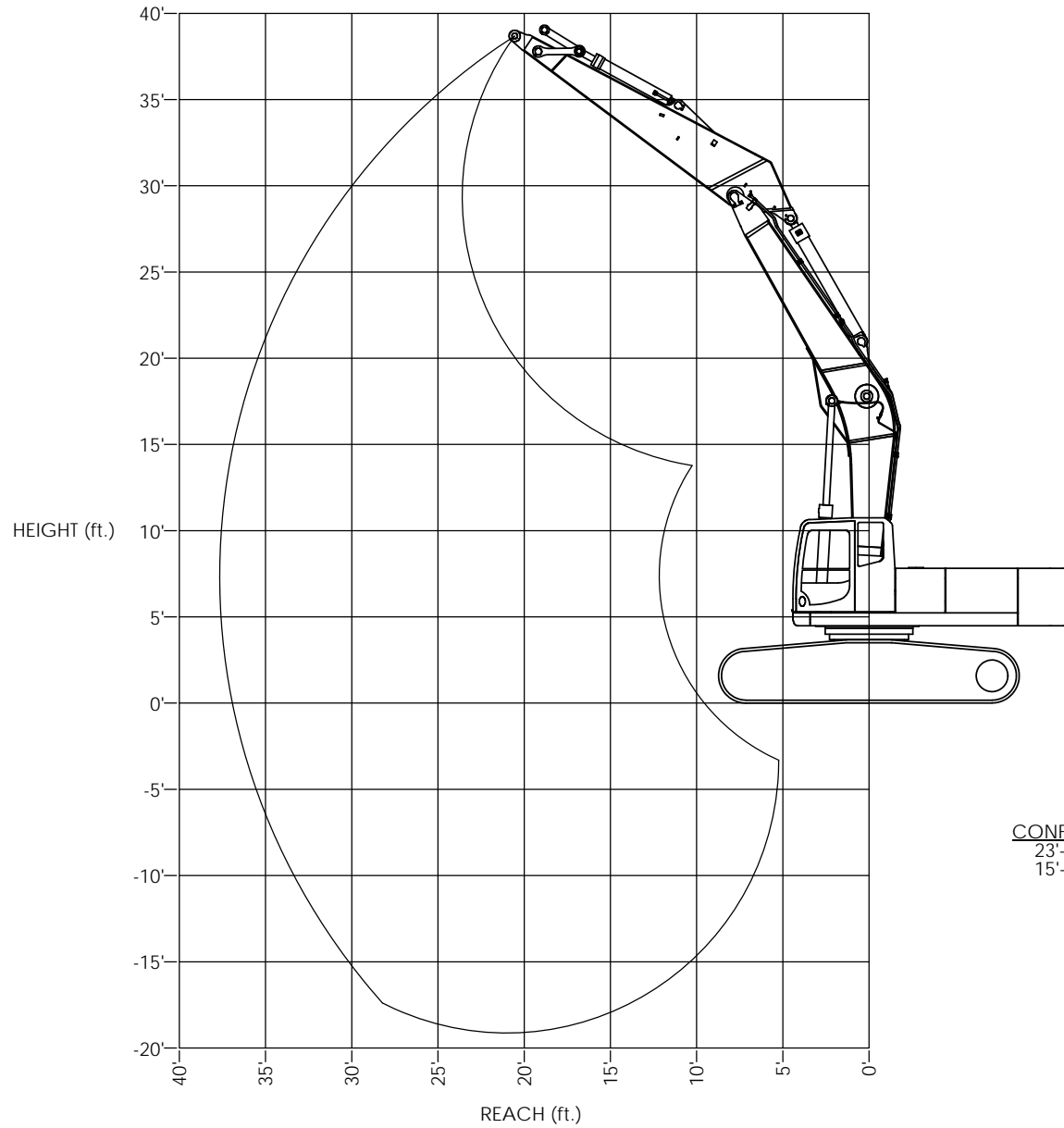

CONFIGURATION:
 23'-2" BOOM (WITH DUAL PIN POSITIONS FOR BOOM CYLINDERS)
 15'-9" ARM

MATERIAL:		



4805 SCOOPY LANE NW
 CARROLL, OHIO 43112
 740-654-5304

The Cutting Edge of Customer Service

<small>PROPRIETARY AND CONFIDENTIAL THE INFORMATION CONTAINED IN THIS DRAWING IS THE SOLE PROPERTY OF COMPANY WRENCH. ANY REPRODUCTION OR TRANSMISSION OF THIS DRAWING WITHOUT THE WRITTEN PERMISSION OF COMPANY WRENCH IS PROHIBITED.</small>	<small>UNLESS OTHERWISE SPECIFIED DIMENSIONS TO DIMENSION LINES ARE AS FOLLOWS:</small>	<small>TITLE:</small> PC450-8 DUAL BOOM PIN RANGE - 15'-9" ARM
	<small>DECIMAL: 80/100" FRACTIONAL: 1/16" ANGLE: 1°</small>	<small>SCALE: 1:40</small> SHEET 1 OF 1

SIZE: D DWG./PART NO.